

ENGINE POWERED TELESCOPIC BOOM LIFTS TB32JN PLUS (TB1060JN PLUS)

Compliant with CE/AS/EAC standards



PRODUCT HIGHLIGHTS

High Capacity

- Plus series boom lift hold up to 1000 lb (restricted)/661lb (unrestricted) platform capacity allowing you to carry up to 3 occupants plus material and tools to get your job done easily

Intelligent Maintenance

- Industry leading 7" screen displays faults and status information, for easy reference, reducing service technician assistance. Workers can complete tasks under the remote guidance of qualified service technicians. Convenient for fleet managers to quickly access live machine and maintenance information

Precision Performance

- The upper control box is equipped with 3 full-proportional handles for gradual control of boom lifting, telescoping, turntable rotation and driving speed. Operate with smooth starting and stopping and precision approach to your worksite target



Standard Features		
Active oscillating function	7-in display screen	4WD × 2WS
Proportional control with 3 joysticks	Automotive-grade sleeves for all pipes	Weighing system
Hydraulic platform leveling	160° Platform rotation	Telematics-ready connector
Tilt protection system	Max tilt rating to 5°	Half mesh (For platform with swinging gate)
Flashing beacon	White noise alarm	2.44 m(8') platform with swing gate
Secondary guarding device	Battery isolator	
Manual storage box	Non-marking tires	
Options & Accessories		
AC power to platform	1.83 m(6') /2.44 m(8') platform with swinging gate	
Platform work light		
Glazier kit(For platform with swinging gate)		

SINOBOOM™

PARTNERS IN ACCESS™

SINOBOOM.COM | SALES@SINOBOOM.COM
32-34 Marni Street, Dandenong South, VIC Australia 3175

ENGINE POWERED TELESCOPIC BOOM LIFTS

TB32JN PLUS (TB1060JN PLUS)/TB32J PLUS (TB1050J PLUS)

Compliant with CE/ANSI/EAC standards

Model	TB32JN Plus (TB1060JN PLUS)
Dimensions	
Max Platform Height	32.3 m (105'12")
Max Working Height	34.3 m (112'6")
Max Horizontal Reach(Restricted/Unrestricted)	17.9 m/20m (58'8"/65'7")
A Stowed Length	12.76 m (41'10")
B Stowed Width	2.49 m (8'2")
C Stowed Height	2.88 m (9'5")
Stowed Length (Transport)	9.73 m (31'11")
Stowed Width (Transport)	2.49 m (8'2")
Stowed Height (Transport)	2.88 m (9'5")
D Wheelbase	3.0 m (9'10")
Ground Clearance	0.46 m (1'6")
Platform Size (L×W×H)	2.44 m×0.91 m×1.1 m (8'×3'×3'7")
Performance	
Max Platform Capacity(Restricted/Unrestricted)	454 kg/300 kg (1,001lbs/661lbs)
Max Platform Occupants(Restricted/Unrestricted)	3 Persons/ 2 Persons
Drive Speed (Stowed)	0~4.8 km/h (0~3 mph)
Drive Speed (Raised)	0~1.1 km/h (0~0.68 mph)
Gradeability	45%
Turntable Rotation	360°/Continuous
Platform Rotation	160°
Tilt Rating	5°
Turning Radius (Inside/Outside)	3.65 m/6.91 m (12'/ 22'8")
Turntable Tail-Swing	1.45 m (4'8")
Max Allowable Side Force	400 N (90 lbf)
Max Allowable Wind Speed	12.5 m/s (28 mph)
Tire Spec/Type	385/65D22.5 (Foam-filled)
Power	
Drive × Steer	4WD × 2WS
Engine	54 kW/2400 rpm/ QSF2.8t3TC72/Cummins/China T3
Hydraulic Tank Capacity	180 L(39.6gal(UK)/47.6gal(US))
Diesel Tank Capacity	140 L (30.8 gal(UK)/37 gal(US))
System Voltage	12 VDC
Weight	
Weight	17,460 kg (38,493lbs)
Standards Compliance	CE/AS/EAC

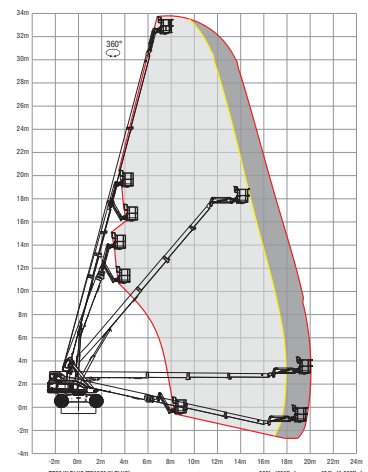
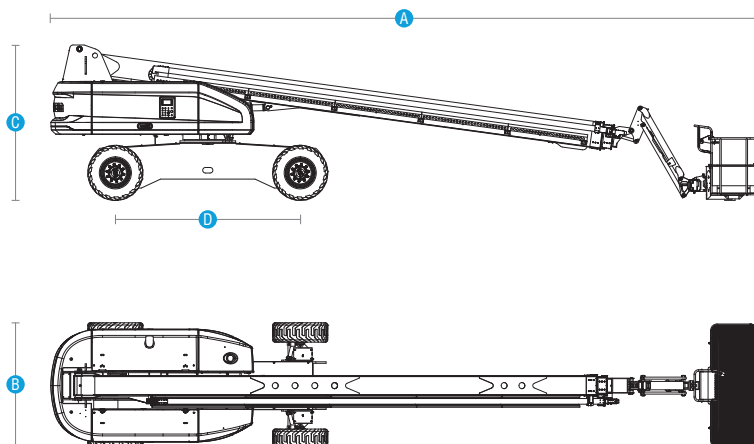

Auckland, Head Office
6-10 Parkway Drive,
Mairangi Bay,
Auckland
(+64) 09 443 2436
sales@yrco.co.nz

Auckland, Mt Wellington
20L Sylvia Park Road,
Mt Wellington,
Auckland
(+64) 09 553 5470
salesmtwell@yrco.co.nz

Waikato
3/31 Chafer Place,
Te Rapa,
Hamilton
(+64) 07 595 0245
saleswaikato@yrco.co.nz

Wellington
8 Broken Hill Road,
Porirua,
Wellington
(+64) 04 212 2456
saleswell@yrco.co.nz

Christchurch
20 Nga Mahi Road,
Sockburn,
Christchurch
(+64) 03 341 6923
saleschch@yrco.co.nz