

PRODUCT HIGHLIGHTS

Suitable for Narrow Spaces

- Narrow body with almost zero tail sweep

Green

- Fully battery-powered, silent, zero emissions, long battery life, especially suitable for indoor work

Precision Performance

- Joysticks with variable proportional control, accuracy in reaching the operation target



Standard Features		
5-in display screen	2WD x 2WS	Proportional control with 2 joysticks
Automotive-grade sleeves for all pipes	Emergency lowering system	Hydraulic platform leveling
Max tilt rating to 5°	Telematics-ready connector	Battery isolator
Half mesh	Fault diagnosis system	Non-marking tires
1.45m(4'9") platform	White noise alarm	
Options & Accessories		
AC power to platform		
Platform work light		

ELECTRIC ARTICULATING BOOM LIFTS

AB14EJ (AB460EJ)

Compliant with CE/ANSI/CSA/AS/EAC standards

Model	AB14EJ (AB460EJ)
Dimensions	
Max Platform Height	14 m (45'11")
Max Working Height	16 m (52'6")
Max Horizontal Reach	7.6 m (24'11")
Max Up and Over Clearance	7.8 m (25'7")
A Stowed Length	6 m (19'8")
B Stowed Width	1.73 m (5'8")
C Stowed Height	2 m (6'7")
Stowed Length (Transport)	6 m (19'8")
Stowed Width (Transport)	1.73 m (5'8")
Stowed Height (Transport)	2 m (6'7")
D Wheelbase	1.9 m (6'3")
Ground Clearance	0.22 m (8.7")
Platform Dimensions(L×W×H)	1.45 m×0.85 m×1.1 m (4'9"×2'9"×3"7")
Performance	
Max Platform Capacity	230 kg (507 lbs)
Max Platform Occupants	2 Persons
Drive Speed (Stowed)	0~5.2 km/h (0~3.2 mph)
Drive Speed (Raised)	0~0.8 km/h (0~0.5 mph)
Gradeability	30%
Turntable Rotation	355°/Non-continuous
Platform Rotation	160°
Tilt Rating	5°
Turning Radius (Inside/Outside)	1.15 m/3.51 m (3'9"/11'6")
Turntable Tail-Swing	0 m
Max Allowable Side Force	400 N (90 lbf)
Max Allowable Wind Speed	12.5 m/s (28 mph)
Tire Spec/Type	240/55D17.5 Foam-filled
Power	
Drive × Steer	2 WD×2 WS
Batteries	48 V, 390 Ah (lead acid battery)
Hydraulic Tank Capacity	40L (8.8 gal (UK)/10.6 gal (US))
System Voltage	12 VDC
Weight	
Weight	7,100 kg (15,653 lbs)
Standards Compliance	CE/ANSI/CSA/AS/EAC

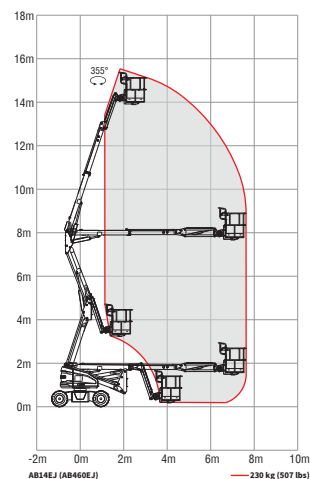
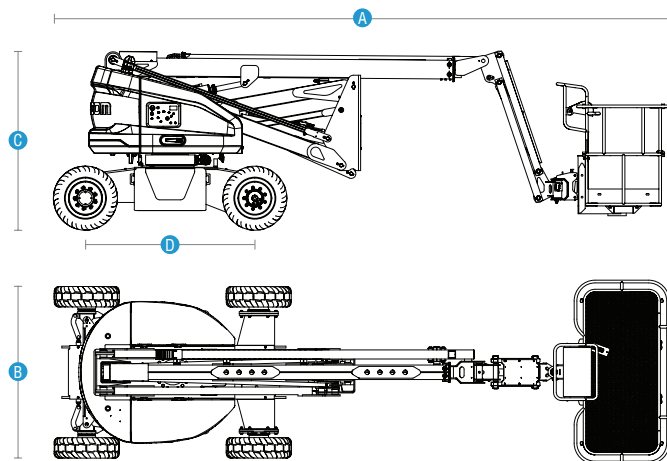

Auckland, Head Office
6-10 Parkway Drive,
Mairangi Bay,
Auckland
(+64) 09 443 2436
sales@yrco.co.nz

Auckland, Mt Wellington
20L Sylvia Park Road,
Mt Wellington,
Auckland
(+64) 09 553 5470
salesmtwell@yrco.co.nz

Waikato
3/31 Chafer Place,
Te Rapa,
Hamilton
(+64) 07 595 0245
saleswaikato@yrco.co.nz

Wellington
8 Broken Hill Road,
Porirua,
Wellington
(+64) 04 212 2456
saleswell@yrco.co.nz

Christchurch
20 Nga Mahi Road,
Sockburn,
Christchurch
(+64) 03 341 6923
saleschch@yrco.co.nz

4C+
CELEBRATING
OVER 40 YEARS
IN BUSINESS

YR Youngman
Richardson