

PRODUCT HIGHLIGHTS

Strong Site Passability Performance

- Machine features oscillating function, combined with power 4WD not only makes it perfect to work at uneven ground, but also greatly improves work efficiency

Precision Performance

- Proportional control with 3 joysticks, operate with smooth starting and stopping and precision approach to your worksite target
- 7-inch screen features one button's fault inquiries, easy for trouble shooting and calibration

High Capacity

- Leading load capacity of 480kg (1058lbs)/250kg (551lbs) among the same class in the industry and max. Platform occupants up to 3 persons make it ideal choice to get job done easily



Standard Features		
Active oscillating function	7-in display screen	4WD x 2WS
Proportional control with 3 joysticks	Automotive-grade sleeves for all pipes	Weighing system
Hydraulic platform leveling	180° Platform rotation	Telematics-ready connector
Tilt protection system	Max tilt rating to 5°	Half mesh (For platform with swinging gate)
Flashing beacon	White noise alarm	
Secondary guarding device	Battery isolator	
Manual storage box	2.44 m(8') platform with swing gate	
Options & Accessories		
AC power to platform	Platform work light	
1.83m(6') /2.44m(8') platform with swinging gate		
Glazier kit(for platform with swinging gate)		

ENGINE POWERED TELESCOPIC BOOM LIFTS

TB42RJ(TB1370RJ)

Compliant with CE/EAC/AS standards

Model	TB42RJ (TB1370RJ)
Dimensions	
Max Platform Height	41.6 m (136'6")
Max Working Height	43.6 m (143'0.5")
Max Horizontal Reach (Restricted/Unrestricted)	21.6 m/23.8m (70'10"/78'1")
A Stowed Length	14.96 m (49'1")
B Stowed Width	2.49 m (8'2")
C Stowed Height	3.15 m (10'4")
Stowed Length (Transport)	12.3 m (40'4")
Stowed Width (Transport)	2.49 m (8'2")
Stowed Height (Transport)	3.15 m (10'4")
D Wheelbase	3.81 m (12'6")
Ground Clearance	0.65 m (2'1.6")
Platform Size (L×W×H)	2.44 m×0.91 m×1.1 m (8'×3'×3'7")
Performance	
Max Platform Capacity(Restricted/Unrestricted)	480 kg/250 kg (1,058 lbs/551 lbs)
Max Platform Occupants(Restricted/Unrestricted)	2 persons and tools/2 persons and tools
Drive Speed (Stowed)	0~4.4 km/h (0~2.7 mph)
Drive Speed (Raised)	0~1 km/h (0~0.62 mph)
Gradeability	40%
Turntable Rotation	360° / Continuous
Platform Rotation	180°
Jib rotation	235° (left 160° / right 75°)
Tilt Rating	5°
Turning Radius (Inside/Outside)	4.37 m/6.81 m (14'4" / 22'4")
Turntable Tail-Swing	1.68 m (5'6")
Max Allowable Side Force	400 N (90 lbf)
Max Allowable Wind Speed	12.5 m/s (28 mph)
Tire Spec/Type	445/50D710 18PR (foam-filled)
Power	
Drive × Steer	4WDx4WS
Engine	54 KW /2400 rpm/ QSF2.8t3TC72/Cummins/China T3 55.4 KW /2600 rpm/ TD2.9 L4/Deutz/EU Stage IIIB, EPA 4 55.8 kW / 2200 rpm/YCF3075-T480/Yuchai/China T4
Hydraulic Tank Capacity	280 L (61.6 gal(UK)/74.0 gal(US))
Diesel Tank Capacity	200 L (44.0 gal(UK)/52.8 gal(US))
System Voltage	12 VDC
Weight	
Weight	22,400 kg (49,383 lbs)

Standards Compliance

CE/EAC/AS

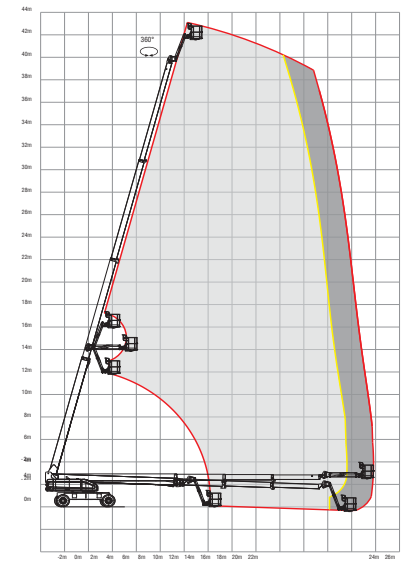
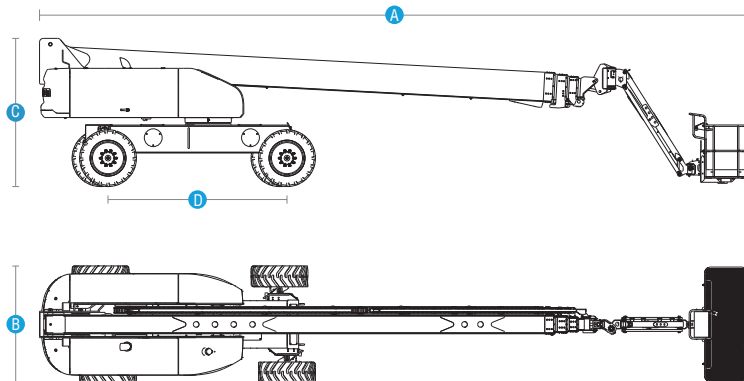

Auckland, Head Office
6-10 Parkway Drive,
Mairangi Bay,
Auckland
(+64) 09 443 2436
sales@yrco.co.nz

Auckland, Mt Wellington
20L Sylvia Park Road,
Mt Wellington,
Auckland
(+64) 09 553 5470
salesmtwell@yrco.co.nz

Waikato
3/31 Chafer Place,
Te Rapa,
Hamilton
(+64) 07 595 0245
saleswaikato@yrco.co.nz

Wellington
8 Broken Hill Road,
Porirua,
Wellington
(+64) 04 212 2456
saleswell@yrco.co.nz

Christchurch
20 Nga Mahi Road,
Sockburn,
Christchurch
(+64) 03 341 6923
saleschch@yrco.co.nz