

PRODUCT HIGHLIGHTS

Excellent Performance

- Up to 35% gradeability, easily handling outdoor needs
- Stable movement, oscillating working at both stowed and raised position

High Efficiency

- 1.6m(5'3") wide platform with one-way extension platform
- One-click leveling, easy work on uneven road surfaces

Easy Maintenance

- Two-sided hatchback door design, for convenient maintenance
- Swing-out engine compartment for easy maintenance



Standard Features		
4 WD × 2 WS	Forklift pockets and lifting points	Proportional control
Manual storage box	Flashing beacon	Emergency lowering system
Emergency stop	Electrophoretic painting	Tilt protection system
Foldable guardrail	Non-marking tires	Trackunit connector
Overload sensing system	Oscillating axle	Fault diagnosis system
White noise alarm	Drivable at full height	
Options & Accessories		
AC power to platform	Platform work light	
EQSS/Protector	Battery isolator	

ENGINE POWERED ROUGH TERRAIN SCISSOR LIFTS

1218RD (4069RD)

Compliant with CE/ANSI/CSA/EAC/AS standards

Model	1218RD (4069RD)
Dimensions	
Max Working Height	14.2 m (46'10.7")
A Max Platform Height	12.2 m (40'0.3")
B Max Horizontal Reach	1.5 m (4'11.1")
C Length-Stowed (With/Without outriggers)	3.8 m/3.19 m (12'5.6"/10'5.6")
D Width-Stowed	1.78 m (5'10")
E Height-Stowed (Rails Folded)	2.1 m (6'10.7")
E Height-Stowed (Rails Unfolded)	2.73 m (8'11.5")
F Wheelbase	2.28 m (7'5.8")
Ground Clearance	0.22 m (8.66")
Platform Size (L×W×H)	2.8 m×1.6 m×1.1 m (9'2.2"×5'3"×3'7.3")
Performance	
Platform Capacity	365 kg (805 lbs)
Extension Platform Capacity	140 kg (309 lbs)
Max Platform Occupants (Indoor/Outdoor)	3 Persons/2 Persons
Drive Speed (Stowed)	0~5.6 km/h (0~3.5 mph)
Drive Speed (Raised)	0~0.48km/h (0~0.3 mph)
Lift Time (Unloaded)	55 s~65 s
Lower Time (Unloaded)	50 s~60 s
Gradeability	35%
Tilt Rating (Front-to-back)	3°
Tilt Rating (Side-to-side, Outriggers Retracted/Deployed)	2°/0.8°
Max Outrigger Levelling (Front-to-back)	5.3° (front)/4.2° (back)
Max Outrigger Levelling (Side-to-side)	11.7°
Turning Radius (Inside/Outside)	2.11 m/4.6 m (6'11.1"/15'1.1")
Tire Spec/Type	26×12-16.5/solid
Power	
Drive × Steer	4 WD×2 WS
Engine	Kubota D1105-E4B-EU-X1
Hydraulic Tank Capacity	72L (15.8 gal (UK)/19 gal (US))
Fuel Tank Capacity	48L (10.6 gal (UK)/12.7gal (US))
Battery	12 V, 60 Ah
System Voltage	12 VDC
Weight	
Weight (With outriggers/Without outriggers)	5,180 kg (11,420 lbs)/ 4,720 kg (10,406 lbs)
Standards Compliance	
CE/ANSI/CSA/EAC/AS	

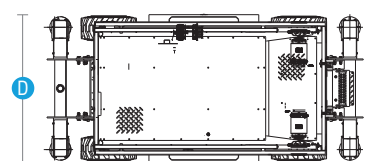
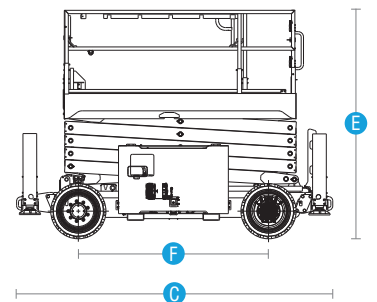
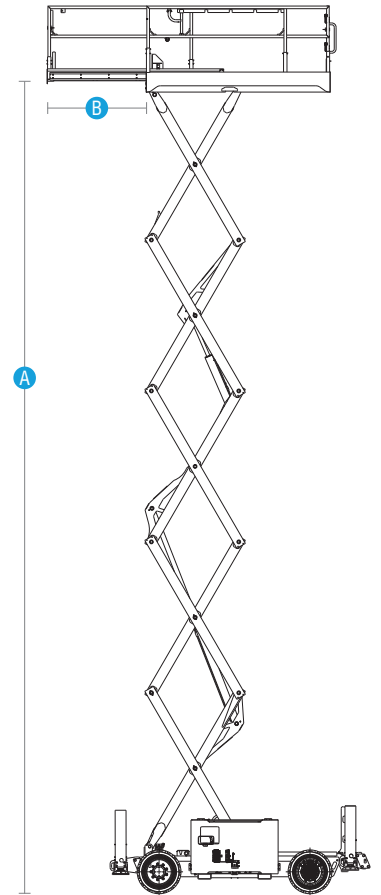

Auckland, Head Office
6-10 Parkway Drive,
Mairangi Bay,
Auckland
(+64) 09 443 2436
sales@yrco.co.nz

Auckland, Mt Wellington
20L Sylvia Park Road,
Mt Wellington,
Auckland
(+64) 09 553 5470
salesmtwell@yrco.co.nz

Waikato
3/31 Chafer Place,
Te Rapā,
Hamilton
(+64) 07 595 0245
saleswaikato@yrco.co.nz

Wellington
8 Broken Hill Road,
Porirua,
Wellington
(+64) 04 212 2456
saleswell@yrco.co.nz

Christchurch
20 Nga Mahi Road,
Sockburn,
Christchurch
(+64) 03 341 6923
saleschch@yrco.co.nz

4C+
CELEBRATING
OVER 40 YEARS
IN BUSINESS

**YR Youngman
Richardson**