

PRODUCT HIGHLIGHTS

Excellent Performance

- Up to 35% gradeability, easily handling outdoor needs

High Efficiency

- 1.6m(5'3") wide platform with one-way extension platform
- One-click leveling, easy work on uneven road surfaces

Easy Maintenance

- Two-sided hatchback door design,for convent maintenai
- Self-diagnose sustem display alarm

Green

- Comfortable working environment without noise pollution
- Meet indoor or emissions-critical site requirements

Economical

- Battery quality assurance, low failure rate and reduced maintenance costs compared with diesel power, which reduces overall operating cost



Standard Features		
2WDX2WS	Forklift pockets and lifting points	Proportional control
Manual storage box	Flashing beacon	Emergency lowering system
Emergency stop	Electrophoretic painting	Tilt protection system
Non-marking tires	Foldable guardrail	Trackunit connector
Overload sensing system	Oscillating axle	Fault diagnosis system
White noise alarm	Drivable at full height	
Options & Accessories		
AC power cable to platform	Platform work light	
Battery isolator	EQSS/Protector	

ELECTRIC ROUGH TERRAIN SCISSOR LIFTS

GTJZ1018RE (3369RE)/GTJZ1218RE (4069RE)

Compliant with CE/ANSI/EAC standards

Model	1018RE (3369RE)
Dimensions	
Max Working Height	12 m (39'4.4")
A Max Platform Height	10 m (32'9.7")
B Max Horizontal Extension	1.5 m (4'11.1")
C Length-Stowed (Outriggers/Without Outriggers)	3.8 m/3.19 m (12'5.6"/10'5.6")
D Width-Stowed	1.77 m (5'9.7")
E Height-stowed (Rail Folded)	1.96 m (6'5.2")
E Height-stowed (Rail Unfolded)	2.59 m (8'6")
F Wheelbase	2.28 m (7'5.8")
Ground Clearance	0.22 m (8.66")
Platform Dimensions (L×W×H)	2.8 m×1.6 m×1.1 m (9'2"×5'3"×3'7")
Performance	
Platform Capacity	450 kg (992 lbs)
Extension Platform Capacity	140 kg (309 lbs)
Platform Allowable Occupants (Indoor/Outdoor)	4 Persons/2 Persons
Drive Speed (Stowed)	0~6 km/h (0~3.7 mph)
Drive Speed (Raised)	0~0.48 km/h (0~0.3 mph)
Lift Time (Unloaded)	42 s~52 s
Lower time (Unloaded)	40 s~50 s
Gradeability	35 %
Tilt Rating (Front to Back)	3°
Tilt Rating (Side to Side, Outrigger Retred/Extend)	2°/0.8°
Max Outrigger Leveling (Front to Back)	5.3° (Front)/4.2° (Back)
Max Outrigger Leveling (Side to Side)	11.7°
Turning Radius (Inside/Outside)	2.11 m/4.6 m (6'11"/15'1")
Tire Size/Type	26×12-16.5/Solid foam-filled
Power	
Drive × Steer	2 WD×2 WS
Batteries	48 V, 390 Ah
Hydraulic Tank Capacity	72L (15.8 gal(UK)/19 gal(US))
System Voltage	48 VDC
Weight	
Weight (Outriggers/Without Outriggers)	4,510 kg (9,943lbs)/4,050 kg (8,929lbs)
Standards Compliance	CE/AS/EAC

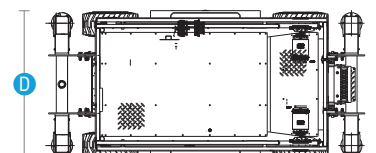
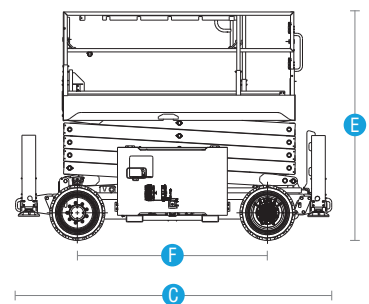
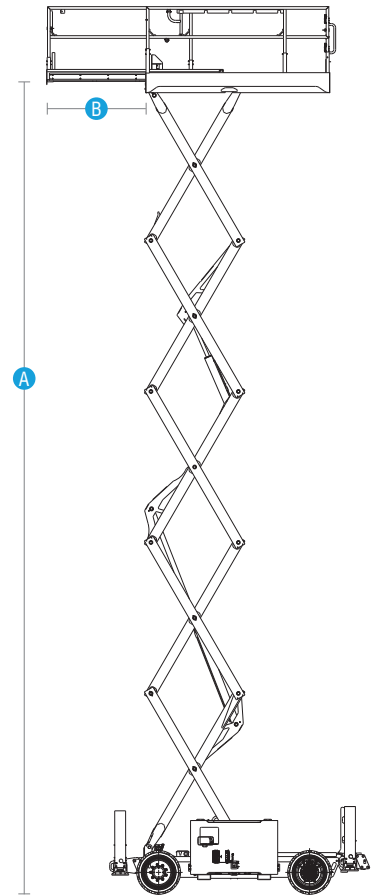

Auckland, Head Office
6-10 Parkway Drive,
Mairangi Bay,
Auckland
(+64) 09 443 2436
sales@yrco.co.nz

Auckland, Mt Wellington
20L Sylvia Park Road,
Mt Wellington,
Auckland
(+64) 09 553 5470
salesmtwell@yrco.co.nz

Waikato
3/31 Chafer Place,
Te Rapa,
Hamilton
(+64) 07 595 0245
saleswaikato@yrco.co.nz

Wellington
8 Broken Hill Road,
Porirua,
Wellington
(+64) 04 212 2456
saleswell@yrco.co.nz

Christchurch
20 Nga Mahi Road,
Sockburn,
Christchurch
(+64) 03 341 6923
saleschch@yrco.co.nz

