

PRODUCT HIGHLIGHTS

Efficient and Environmentally Friendly

- Higher work efficiency
- Environmental protection, zero emissions

Reduced Maintenance Costs

- The short design of sliding rail makes debris easy to clean
- Rapid, convenient transportation with two-way forklift slot
- Lower cost of ownership with highly versatile parts and components

Reliable Performance

- New wide scissor design, for a more stable working-at-height experience
- Bumper rail and indented sliding rail designed for anti-scratch



Standard Features		
2WD×2WS	Maintenance-free battery	Fault diagnosis system
Non-marking tires	Proportional control	Emergency lowering system
Emergency stop	Electrophoretic painting	Tilt protection system
Flashing beacon	Forklift pockets and lifting points	Overload sensing system
Foldable guardrail	Automatic pothole protection	Manual storage box
Drivable at full height	Bumper rails	
White noise alarm	Trackunit connector	
Options & Accessories		
RCBO	AC drive motor	EQSS/Protector
AC power to platform	Battery isolator	
Lithium battery	Platform work light	

ELECTRIC SERIES SCISSOR LIFTS

1012E (3346E)

Compliant with CE/ANSI/CSA/AS/EAC standards

Model	1012E (3346E)
Dimensions	
Max Working Height(Indoor/Outdoor)	12 m (39'4.5")
A Max Platform Height(Indoor/Outdoor)	10 m (32'10")
B Platform Extension	0.9 m (3')
C Length-Stowed	2.45 m (8')
D Width-Stowed	1.17 m (3'10")
E Height-stowed (Rails Folded)	1.86 m (6'1")
E Height-stowed (Rails Unfolded)	2.48 m (8'1.6")
F Wheelbase	1.88 m (6'2")
Ground Clearance(Pothole Guard Stowed)	0.1 m (4")
Ground Clearance(Pothole Guard De-ployed)	25 mm (0.98")
Platform Size (L×W×H)	2.30 m×1.15 m×1.1 m (7'6.5"×3'9"×3'7")
Performance	
Platform Capacity	320 kg (705.6 lbs)
Extension Platform Capacity	120 kg (265 lbs)
Max Occupants (Indoor/Outdoor)	2 Persons/1 Person
Drive Speed (Stowed)	0~4 km/h (0~2.5 mph)
Drive Speed (Raised)	0~0.8 km/h (0~0.5 mph)
Lift Time (Unloaded)	53s-58s
Lower Time (Unloaded)	40s-45s
Gradeability	25%
Max Allowable Inclination (front-to-back/side-to-side)	3°/1.5°
Turning Radius (Inside/Outside)	0/2.35 m (0 / 7'8.5")
Tire Spec/Type	380×125 mm/solid (15"×5")
Power	
Drive × Steer	2WD×2 WS
Power Source (V/kW)	24V DC , 3.3 kW
Drive Motor (V/kW)	24 V DC / 0.85 kW 24 V AC / 0.7 kW
Hydraulic Tank Capacity	15 L (3.3 gal (UK) /4.0 gal (US))
Batteries	24 V, 220 Ah (Lead acid battery) 25.6 V, 200 Ah (Lithium battery)
Charger (Input/Output)	100~240 V AC/30 A
Weight	
Weight (Indoor/Outdoor)	2,815 kg (6,206lbs)
Standards Compliance	CE/ANSI/CSA/AS/EAC

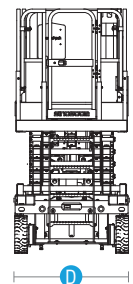
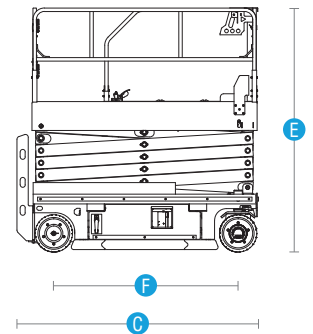
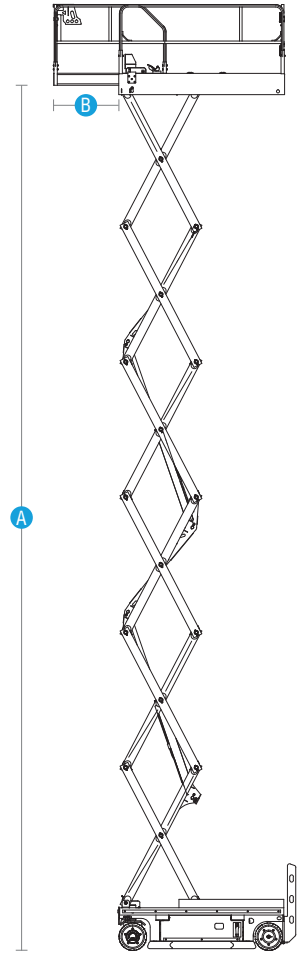

Auckland, Head Office
6-10 Parkway Drive,
Mairangi Bay,
Auckland
(+64) 09 443 2436
sales@yrco.co.nz

Auckland, Mt Wellington
20L Sylvia Park Road,
Mt Wellington,
Auckland
(+64) 09 553 5470
salesmtwell@yrco.co.nz

Waikato
3/31 Chafer Place,
Te Rapa,
Hamilton
(+64) 07 595 0245
saleswaikato@yrco.co.nz

Wellington
8 Broken Hill Road,
Porirua,
Wellington
(+64) 04 212 2456
saleswell@yrco.co.nz

Christchurch
20 Nga Mahi Road,
Sockburn,
Christchurch
(+64) 03 341 6923
saleschch@yrco.co.nz

4C+
CELEBRATING
OVER 40 YEARS
IN BUSINESS

**YR Youngman
Richardson**