

# ELECTRIC SCISSOR LIFTS 0808E(2732E)

Compliant with CE/ANSI/CSA/EAC/AS/KCS standards



## PRODUCT HIGHLIGHTS

### Efficient and Environmentally Friendly

- Higher work efficiency
- Environmental protection, zero emissions

### Reduced Maintenance Costs

- The short design of sliding rail makes debris easy to clean
- Rapid, convenient transportation with two-way forklift slot
- Lower cost of ownership with highly versatile parts and components

### Reliable Performance

- New wide scissor design, for a more stable working-at-height experience
- Bumper rail and indented sliding rail designed for anti-scratch



Standard Features		
2WD×2WS	Maintenance-free battery	Fault diagnosis system
Non-marking tires	Proportional control	Emergency lowering system
Emergency stop	Electrophoretic painting	Tilt protection system
Flashing beacon	Forklift pockets and lifting points	Overload sensing system
Foldable guardrail	Automatic pothole protection	Manual storage box
Drivable at full height	Bumper rails	
White noise alarm	Trackunit connector	
Options & Accessories		
RCBO	Battery isolator	
AC power to platform	EQSS/Protector	
AC drive motor		

**SINOBOOM™**

**PARTNERS IN ACCESS™**

SINOBOOM.COM | SALES@SINOBOOM.COM  
32-34 Marni Street, Dandenong South, VIC Australia 3175

# ELECTRIC SCISSOR LIFTS 0808E(2732E)

Compliant with CE/ANSI/CSA/EAC/AS/KCS standards

Model	0808E (2732E)
<b>Dimensions</b>	
Max Working Height (Indoor/Outdoor)	10.1 m/8 m (33'2"/26'3")
A Max Platform Height (Indoor/Outdoor)	8.1 m/6 m (26'7"/19'8")
B Platform Extension	0.9 m (3')
C Length-Stowed	2.46 m (8')
D Width-Stowed	0.83 m (2'8.7")
E Height-Stowed (Rails Folded)	1.96 m (6'5")
E Height-Stowed (Rails Unfolded)	2.36 m (7'9")
F Wheelbase	1.88 m (6'2")
Ground Clearance (Pothole Guard Stowed)	0.1 m (4")
Ground Clearance (Pothole Guard Deployed)	0.025 m (0.98")
Platform Size (L×W×H)	2.3 m×0.8 m×1.1 m (7'6.5"×2'7.5"×3'7")
<b>Performance</b>	
Platform Capacity	250 kg (551 lbs)
Extension Platform Capacity	120 kg (265 lbs)
Max Platform Occupants (Indoor/Outdoor)	2 Persons /1 Person
Drive Speed (Stowed)	0~4 km/h (0~2.5 mph)
Drive Speed (Raised)	0~0.8 km/h (0~0.5 mph)
Lift Time (Unloaded)	30 s-35 s
Lower Time (Unloaded)	34 s-39 s
Gradeability	25 %
Max Allowable Inclination (front-to-back/side-to-side)	3°/1.5°
Turning Radius (Inside/Outside)	0m /2.1 m (0/6'10.7")
Tyre Size/Type	380×125 mm (15×5')/solid
<b>Power</b>	
Drive×Steer	2 WD×2 WS
Power Source (V/kW)	24 V/3.3 kW
Drive Motor (V/kW)	24 V DC/0.85 kW 24 V AC /0.7 kW
Hydraulic Tank Capacity	15L (3.3 gal(UK) / 4.0 gal(US))
Batteries	24 V, 220 Ah (Lead acid battery)
Charger (Input/Output)	100~240 V AC/30 A
<b>Weight</b>	
Weight(Indoor/Outdoor)	2,265 kg (4,994 lbs)
Standards Compliance	CE/ANSI/CSA/AS/EAC/KCS

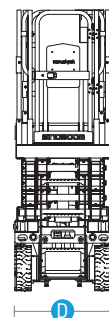
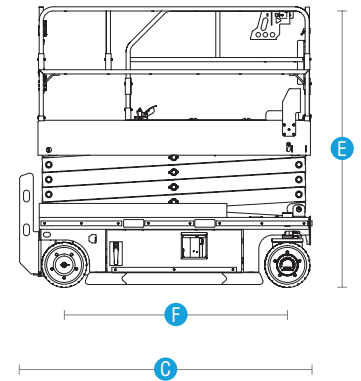
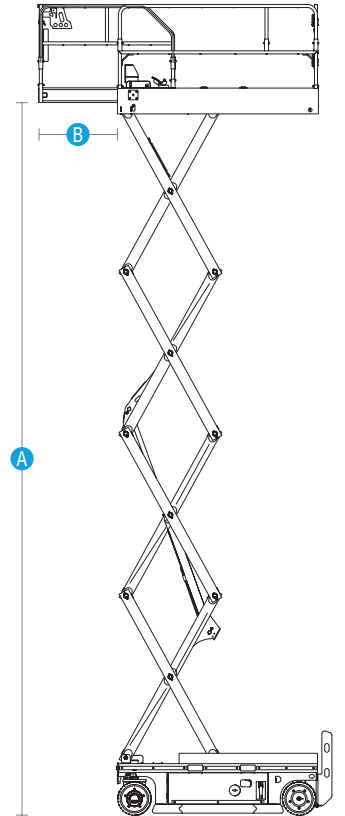

**Auckland, Head Office**  
6-10 Parkway Drive,  
Mairangi Bay,  
Auckland  
(+64) 09 443 2436  
sales@yrco.co.nz

**Auckland, Mt Wellington**  
20L Sylvia Park Road,  
Mt Wellington,  
Auckland  
(+64) 09 553 5470  
salesmtwell@yrco.co.nz

**Waikato**  
3/31 Chafer Place,  
Te Rapa,  
Hamilton  
(+64) 07 595 0245  
saleswaikato@yrco.co.nz

**Wellington**  
8 Broken Hill Road,  
Porirua,  
Wellington  
(+64) 04 212 2456  
saleswell@yrco.co.nz

**Christchurch**  
20 Nga Mahi Road,  
Sockburn,  
Christchurch  
(+64) 03 341 6923  
saleschch@yrco.co.nz

**4C+**  
CELEBRATING  
OVER 40 YEARS  
IN BUSINESS

**YR Youngman  
Richardson**